

### FEATURES

#### Force/measure functions

FIMV, FVMI, FVMV, FIMI, FNMV

#### Force/measure voltage range $\pm 11$ V

#### 4 user programmable force/measure current ranges

$\pm 4 \mu\text{A}$ ,  $\pm 40 \mu\text{A}$ ,  $\pm 400 \mu\text{A}$ ,  $\pm 4 \text{mA}$  (external resistors)

#### 2 user programmable extended current ranges

Up to 6 mA without external driver

Higher currents with external driver

#### Clamp circuitry and window comparators on board

#### Guard amplifier

#### 64-lead LQFP package

### APPLICATIONS

#### Automatic test equipment

Per pin PMU, shared pin PMU, device power supply instrumentation

Source measure, parametric measurement, precision measurement

### GENERAL DESCRIPTION

The AD5520 is a single-channel, per pin parametric measurement unit (PPMU) for use in semiconductor automatic test equipment. The part is also suited for use as a source measurement unit for instrumentation applications. It contains programmable modes to force a pin voltage and measure the corresponding current, or force a current and measure the voltage. The AD5520 can force/measure over a  $\pm 11$  V range or user-programmable currents up to  $\pm 4$  mA with its on-board force amplifier. An external amplifier is required for wider current ranges. The device provides a force sense capability to ensure accuracy at the tester pin. A guard output is also available to drive the shield of a force/sense pair. The AD5520 is available in a 64-lead LQFP package.

### FUNCTIONAL BLOCK DIAGRAM

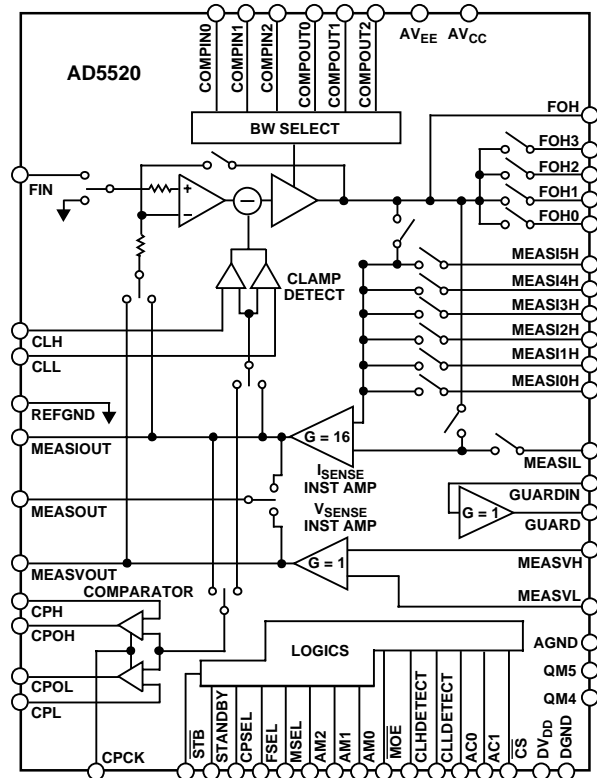

Figure 1.

#### Rev. B

Information furnished by Analog Devices is believed to be accurate and reliable. However, no responsibility is assumed by Analog Devices for its use, nor for any infringements of patents or other rights of third parties that may result from its use. Specifications subject to change without notice. No license is granted by implication or otherwise under any patent or patent rights of Analog Devices. Trademarks and registered trademarks are the property of their respective owners.

## TABLE OF CONTENTS

Features .....	1	Force Control Amplifier .....	15
Applications.....	1	Comparator Function and Strobing .....	15
General Description .....	1	Clamp Function.....	15
Functional Block Diagram .....	1	High Current Ranges .....	15
Specifications.....	3	Circuit Operation .....	16
Timing Characteristics.....	6	Force Voltage.....	16
Absolute Maximum Ratings.....	7	Measure Current.....	16
ESD Caution.....	7	Force Current.....	17
Pin Configuration and Function Descriptions.....	8	Measure Voltage .....	17
Typical Performance Characteristics .....	10	Short Circuit Protection .....	17
Theory of Operation .....	13	Settling Time Considerations .....	18
Interface .....	14	PCB Layout and Power Supply Decoupling.....	19
Standby Mode .....	14	Typical Connection Circuit for the AD5520 .....	20
Force Voltage or Force Current .....	14	Typical Application Circuit.....	21
Measured Parameter .....	14	Evaluation Board for the AD5520.....	22
Current Ranges .....	14	Outline Dimensions .....	24
Rs Selection.....	14	Ordering Guide .....	24

## REVISION HISTORY

### 9/05—Rev. A to Rev. B

Updated Format.....	Universal
Changes to Features.....	1
Changes to Figure 1.....	1
Changes to Specifications.....	3
Changes to Force Current Section.....	17
Changes to Figure 26 .....	20
Updated Outline Dimensions .....	24
Changes to Ordering Guide .....	24

### 10/03—Rev. 0 to Rev. A

Changes to Specifications.....	3
Updated Ordering Guide .....	5

### 9/03—Revision 0: Initial Version

## SPECIFICATIONS

$AV_{CC} = +15\text{ V} \pm 5\%$ ,  $AV_{EE} = -15\text{ V} \pm 5\%$ ,  $DV_{DD} = 5\text{ V} \pm 10\%$ ,  $AGND = 0\text{ V}$ ,  $REFGND = 0\text{ V}$ ,  $DGND = 0\text{ V}$ . All specifications  $0^\circ\text{C}$  to  $70^\circ\text{C}$ , unless otherwise noted.

**Table 1.**

Parameter	Min	Typ <sup>1</sup>	Max	Unit	Test Conditions/Comments
<b>VOLTAGE FORCE MODE</b>					
Force Control Output Voltage Range	$\pm 11$			V	$R_{LOAD} = 10\text{ k}\Omega$ , $C_{LOAD} = 50\text{ pF}$
FOH Output Impedance		70		$\Omega$	
FOH0		2.5		$\text{k}\Omega$	
FOH1		3		$\text{k}\Omega$	
FOH2		500		$\Omega$	
FOH3		60		$\Omega$	
Input Offset Error		$\pm 1$	$\pm 5$	mV	
Input Offset Error Temperature Coefficient		$\pm 10$		$\mu\text{V}/^\circ\text{C}$	
Gain Error			1	%	
Clamp Current Error <sup>2</sup>			$\pm 1$	% FS	of FIN
<b>CURRENT MEASURE/FORCE</b>					
FOH0		$\pm 4$		$\mu\text{A}$	Suggested values; set with external sense resistors MODE0, $R_S = 125\text{ k}\Omega$
FOH1		$\pm 40$		$\mu\text{A}$	MODE1, $R_S = 12.5\text{ k}\Omega$
FOH2		$\pm 400$		$\mu\text{A}$	MODE2, $R_S = 12.5\text{ k}\Omega$
FOH3		$\pm 4$		mA	MODE3, $R_S = 125\text{ }\Omega$
<b>CURRENT MEASURE MODE</b>					
High Sense Input Range, $V_{MEASixH}$			$\pm 11$	V	$+11\text{ V} > V_{FOL} > -11\text{ V}$
Linearity <sup>3</sup>			$\pm 0.01$	% FSR	
Input Bias Current		$\pm 1$	$\pm 3$	nA	
Input Bias Current Drift <sup>1</sup>		50		$\text{pA}/^\circ\text{C}$	
Output Offset Error			$\pm 100$	mV	MODE0 ( $\pm 4\text{ }\mu\text{A}$ )
			$\pm 100$	mV	MODE1 ( $\pm 40\text{ }\mu\text{A}$ )
			$\pm 100$	mV	MODE2 ( $\pm 400\text{ }\mu\text{A}$ )
			$\pm 100$	mV	MODE3 ( $\pm 4\text{ mA}$ )
Output Offset Error Temperature Coefficient		$\pm 10$		$\mu\text{V}/^\circ\text{C}$	
Gain Error		$\pm 0.1$	$\pm 0.35$	%	Gain of 16
Gain Error Temperature Coefficient <sup>4</sup>		30		$\text{ppm}/^\circ\text{C}$	
MEASIOU Output Load Current		$\pm 4$		mA	
CMRR		95		dB	@ DC
<b>CURRENT FORCE MODE</b>					
Input Offset Error			$\pm 10$	mV	with MODE0, MODE1, MODE2, MODE3
Gain Error			1	%	
Clamp Voltage Error <sup>2</sup>			$\pm 1$	% FS	of FIN
<b>VOLTAGE MEASURE MODE</b>					
Differential Input Range			$\pm 11$	V	MEASVL $+11\text{ V} > V_{MEASVH}$ to $V_{MEASVL} > -11\text{ V}$ FIN = 0 V, measured @ MEASVOUT
Low Sense Input Voltage Range		$\pm 100$		mV	
Linearity <sup>3</sup>			+0.005	% FSR	
Input Offset Error		$\pm 5$	$\pm 10$	mV	
Input Offset Error Temperature Coefficient <sup>1</sup>		$\pm 15$		$\mu\text{V}/^\circ\text{C}$	
Gain Error		$\pm 0.03$	$\pm 0.15$	%	Gain of 1
Gain Error Temperature Coefficient <sup>4</sup>		2		$\text{ppm}/^\circ\text{C}$	
Input Bias Current		$\pm 1$	$\pm 3$	nA	
Input Bias Current Drift <sup>4</sup>		50		$\text{pA}/^\circ\text{C}$	
MEASVOUT Output Load Current		$\pm 4$		mA	
CMRR <sup>4</sup>		73		dB	@ DC

# AD5520

Parameter	Min	Typ <sup>1</sup>	Max	Unit	Test Conditions/Comments
AMPLIFIER SETTling TIME <sup>4,5</sup>					
$V_{SENSE}$ Amp		20		$\mu\text{s}$	to 0.2%
$I_{SENSE}$ Amp		12		$\mu\text{s}$	to 0.2%
LOOP SETTling <sup>4,5</sup>					Settling to within 0.024% of 8 V step
COMPIN2 = 100 pF		450	600	$\mu\text{s}$	MODE0
		285	390	$\mu\text{s}$	MODE1
		170	240	$\mu\text{s}$	MODE2, MODE3
COMPIN1 = 1000 pF		2	2.5	ms	MODE0
		1.8	2.4	ms	MODE1, MODE2, MODE3
COMPIN0 = 3000 pF		5.75	8.7	ms	MODE0, MODE1, MODE2, MODE3
SLEW RATE <sup>4,5</sup>		50		mV/ $\mu\text{s}$	COMPIN2 = 100 pF
		4.3		mV/ $\mu\text{s}$	COMPIN1 = 1000 pF
		1.28		mV/ $\mu\text{s}$	COMPIN0 = 3000 pF
COMPARATOR					
CPH, CPL Input Range			$\pm 11$	V	$V_{CPH} > V_{CPL}$
Input Offset			$\pm 7$	mV	
GUARD DRIVER					
Output Voltage			$\pm 11$	V	Capacitive load only
Output Impedance		130		$\Omega$	
Output Offset Voltage		400		mV	
Load Current <sup>4</sup>		$\pm 4$		mA	
Output Settling Time <sup>4</sup>		0.5	2	$\mu\text{s}$	100 pF capacitive load
ANALOG REFERENCE INPUTS					
Force Control Input Range	$\pm 11$			V	$V_{CLH} > V_{CLL}$
Force Control Input Impedance		1		M $\Omega$	
Clamp Control Input Range	$\pm 11$			V	
Clamp Control Input Impedance		1		M $\Omega$	
Comparator Threshold Input Range	$\pm 11$			V	
Comparator Threshold Input Impedance		1		M $\Omega$	
Input Capacitance <sup>4</sup>		3		pF	
LEAKAGE CURRENT					
MEAS <sub>ixx</sub> , MEAS <sub>Vx</sub> , MEAS <sub>OUT</sub> Leakage		$\pm 3$	$\pm 20$	nA	
ANALOG MEASUREMENT OUTPUTS					
Voltage Measure Output Impedance		2		$\Omega$	
Current Measure Output Impedance		3		$\Omega$	
Multiplexed Sense Output Impedance		1		k $\Omega$	
Input Capacitance					
MEAS <sub>ixH</sub> , MEAS <sub>VH</sub> , FOH <sub>x</sub>		8		pF	
LOGIC INPUTS					
Input Current			$\pm 1$	$\mu\text{A}$	All digital inputs together
Input Low Voltage, $V_{INL}$			0.8	V	
Input High Voltage, $V_{IHL}$	2.0			V	
Input Capacitance <sup>4</sup>		3		pF	
LOGIC OUTPUTS					
Output Low Voltage, $V_{OL}$ <sup>4</sup>			0.4	V	$I_{SINK} = 2 \text{ mA}$
Output High Voltage, $V_{OH}$ <sup>4</sup>	2.4			V	$I_{SOURCE} = 2 \text{ mA}$

Parameter	Min	Typ <sup>1</sup>	Max	Unit	Test Conditions/Comments
<b>POWER REQUIREMENTS</b>					
AV <sub>CC</sub>	14.25	15	15.75	V	for specific performance <sup>6</sup>
AV <sub>EE</sub>	-14.25	-15	+15.75	V	
Power Supply Rejection Ratio, PSRR <sup>1</sup>					
FOH		-25		dB	100 kHz
		-16		dB	500 kHz
		-15		dB	1 MHz
MEASOUT		-55		dB	100 kHz
		-10		dB	500 kHz
DC PSR		90		dB	
DV <sub>DD</sub>		5		V	
I <sub>AVCC</sub>			12	mA	
I <sub>AVEE</sub>			12	mA	
I <sub>DVDD</sub>			0.5	mA	Digital inputs at supply rails

<sup>1</sup> Typical values are at 25°C and nominal supply, unless otherwise noted.

<sup>2</sup> Full-scale = 11 V.

<sup>3</sup> Full-scale range = 22 V.

<sup>4</sup> Guaranteed by design and characterization, but not subject to production test.

<sup>5</sup> Force control amplifier dominates slew rate and settling time.

<sup>6</sup> Operational with ±12 V supplies, force/measure range is reduced to ±8.5 V.

## TIMING CHARACTERISTICS

$AV_{CC} = +15\text{ V} \pm 5\%$ ,  $AV_{EE} = -15\text{ V} \pm 5\%$ ,  $AGND = 0\text{ V}$ ,  $REFGND = 0\text{ V}$ ,  $DGND = 0\text{ V}$ . All specifications  $0^\circ\text{C}$  to  $70^\circ\text{C}$ , unless otherwise noted.<sup>1,2</sup>

Table 2.

Parameter	$DV_{DD}$		Unit	Conditions/Comments
	$5\text{ V} \pm 10\%$	$3.3\text{ V}$		
$t_1$	0	0	ns min	$\overline{CS}$ falling edge to $\overline{STB}$ falling edge setup time
$t_2$	30	200	ns min	$\overline{STB}$ pulse width
$t_3$	40	70	ns min	$\overline{STB}$ rising edge to $\overline{CS}$ rising edge setup time
$t_4$	0	40	ns min	Data setup time
$t_5$	550	560	ns min	$\overline{CS}$ falling edge to CPCK rising edge setup time
$t_6$	320	320	ns min	CPCK pulse width
$t_7$	450	500	ns min	CPCK to $\overline{STB}$ falling edge setup time
$t_8$	150	800	ns min	$\overline{STB}$ rising edge to QMx, CLxDETECT valid
$t_9$	100	440	ns min	$\overline{STB}$ rising edge to CPOH, CPOL valid
$t_{10}$	240	240	$\mu\text{s}$ min	Comparator setup time, MODE2, MODE3 settling
$t_{11}$	150	500	ns min	Comparator hold time
$t_{12}$	100	440	ns min	Comparator output delay time
$t_{13}$	320	320	ns min	Comparator strobe pulse width

<sup>1</sup> See Figure 2.

<sup>2</sup> All input signals are specified with  $t_r = t_f = 1\text{ ns}$  (10% to 90% of  $V_{DD}$ ) and timed from a voltage level of  $(V_{IL} + V_{IH})/2$ .

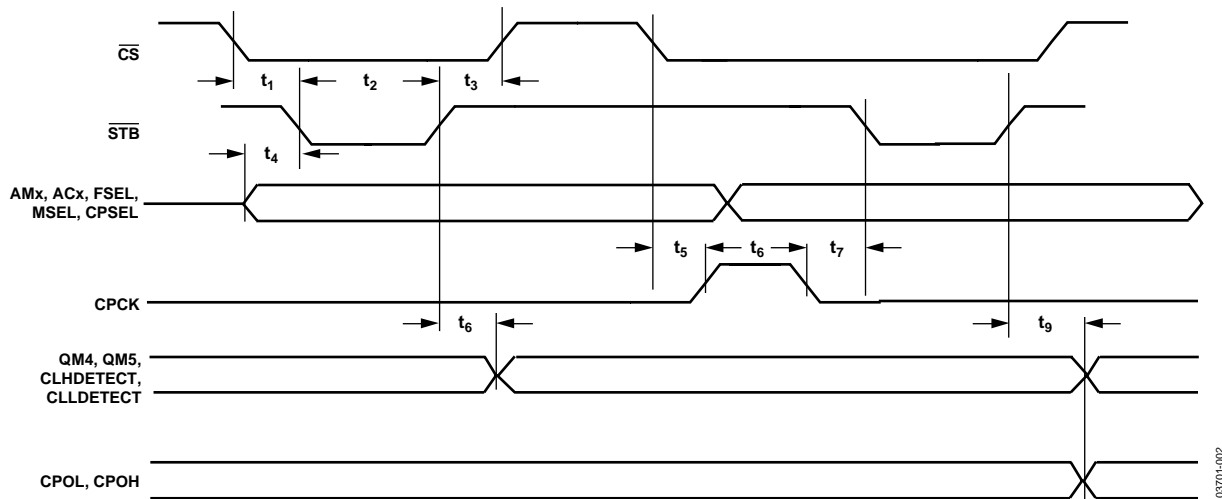

Figure 2. Timing Diagram

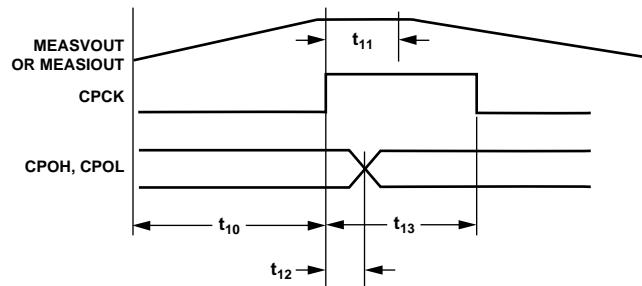

Figure 3. Comparator Timing

## ABSOLUTE MAXIMUM RATINGS

$T_A = 25^\circ\text{C}$ , unless otherwise noted.

**Table 3.**

Parameter	Rating
$AV_{CC}$ to $AV_{EE}$	34 V
$AV_{CC}$ to AGND	-0.3 V, +17 V
$AV_{EE}$ to AGND	+0.3 V, -17 V
$DV_{DD}$	-0.3 V to +6 V
Digital Inputs to DGND	-0.3 V to $DV_{DD} + 0.3$ V
Analog Inputs to AGND	$AV_{CC} + 0.3$ V to $AV_{EE} - 0.3$ V
CLH to CLL	-0.3 V to +34 V
CPH to CPL	-0.3 V to +34 V
REFGND, DGND	$AV_{CC} + 0.3$ V to $AV_{EE} - 0.3$ V
Operating Temperature Range	
Commercial (J Version)	0°C to 70°C
Storage Temperature Range	-65°C to +150°C
Maximum Junction Temperature, ( $T_J$ max)	150°C
Package Power Dissipation	$(T_J \text{ max} - T_A)/\theta_{JA}$
Thermal Impedance $\theta_{JA}$	47.8°C /W
Lead Temperature (Soldering 10 sec)	300°C
IR Reflow, Peak Temperature	220°C

Stresses above those listed under Absolute Maximum Ratings may cause permanent damage to the device. This is a stress rating only; functional operation of the device at these or any other conditions above those indicated in the operational section of this specification is not implied. Exposure to absolute maximum rating conditions for extended periods may affect device reliability.

### ESD CAUTION

ESD (electrostatic discharge) sensitive device. Electrostatic charges as high as 4000 V readily accumulate on the human body and test equipment and can discharge without detection. Although this product features proprietary ESD protection circuitry, permanent damage may occur on devices subjected to high energy electrostatic discharges. Therefore, proper ESD precautions are recommended to avoid performance degradation or loss of functionality.



## PIN CONFIGURATION AND FUNCTION DESCRIPTIONS

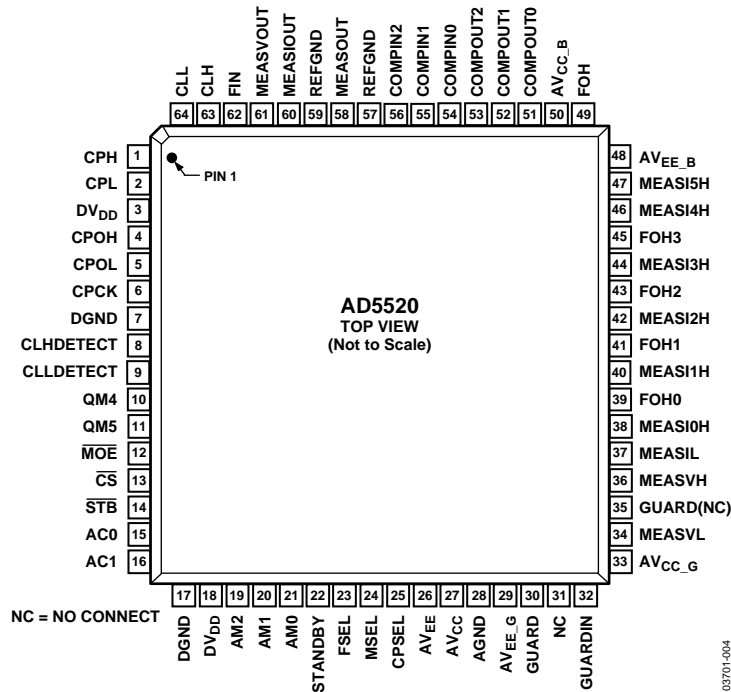

Figure 4. Pin Configuration

Table 4. Pin Function Descriptions

Pin No.	Mnemonic	Description
1	CPH	Upper Comparator Threshold Voltage Input, CPH > CPL.
2	CPL	Lower Comparator Threshold Voltage Input, CPL < CPH.
3, 18	DV <sub>DD</sub>	Digital Supply Voltage.
4	CPOH	Logic Output. When high, indicates MEASVOUT or MEASIOOUT > CPH.
5	CPOL	Logic Output. When high, indicates MEASVOUT or MEASIOOUT < CPL.
6	CPCK	Logic Input. Used to initiate comparator sampling and update CPOH and CPOL.
7, 17	DGND	Digital Ground.
8	CLHDETECT	Logic Output. When high, indicates upper clamp active. See the Clamp Function section.
9	CLLDETECT	Logic Output. When high, indicates lower clamp active. See the Clamp Function section.
10	QM4	Logic Output. When high, indicates current range Mode 4 is enabled. May be used to drive external relay or switch. See the High Current Ranges section.
11	QM5	Logic Output. When high, indicates current range Mode 5 is enabled. May be used to drive external relay or switch. See the High Current Ranges section.
12	$\overline{\text{MOE}}$	Active Low MEASOUT Enable.
13	$\overline{\text{CS}}$	Active Low Logic Input. The device is selected when this pin is low. See the Interface section.
14	$\overline{\text{STB}}$	Active Low Logic Input. Used in conjunction with CPCK and $\overline{\text{CS}}$ to configure the device for different configurations. Rising edge of $\overline{\text{STB}}$ triggers sequence inputs. See the Interface section.
15	AC0	Logic Input. Used in conjunction with AC1 to select one of three external compensation capacitors. See the Force Control Amplifier section.
16	AC1	Logic Input. Used in conjunction with AC0 to select one of three external compensation capacitors. See the Force Control Amplifier section.
19	AM2	Logic Input. Used in conjunction with AM1 and AM0 to select one of six current ranges or to enable standby mode. See the Current Ranges section.
20	AM1	Logic Input. Used in conjunction with AM2 and AM0 to select one of six current ranges or to enable standby mode. See the Current Ranges section.
21	AM0	Logic Input. Used in conjunction with AM2 and AM1 to select one of six current ranges or to enable standby mode. See the Current Ranges section.
22	STANDBY	Logic Input. When high, device is in standby mode of operation. See the Standby Mode section.



Pin No.	Mnemonic	Description
23	FSEL	Logic Input. Force mode select. Used to select between current or voltage force operation. See the Force Voltage or Force Current section.
24	MSEL	Logic Input. Measure mode select. Used to connect MEASOUT to either MEASIOUT when high or MEASVOUT when low.
25	CPSEL	Logic Input. Comparator select. Used to compare CPL, CPH to MEASVOUT when low, or to MEASIOUT when high. See the Comparator Function and Strobing section.
26	AV <sub>EE</sub>	Most Negative Supply Voltage.
27	AV <sub>CC</sub>	Most Positive Supply Voltage.
28	AGND	MEASx Input Ground.
29	AV <sub>EE,G</sub>	Most Negative Supply Voltage.
30	GUARD	Guard Output.
31	NC	No Connect.
32	GUARDIN	Guard Input.
33	AV <sub>CC,G</sub>	Most Positive Supply Voltage.
34	MEASVL	DUT Voltage Sense Inputs (Low Sense).
35	GUARD(NC)	No Connect.
36	MEASVH	DUT Voltage Sense Inputs (High Sense).
37	MEASIL	DUT Current Sense Inputs (Low Sense).
38	MEASIOH	DUT Current Sense Inputs (High Sense).
39	FOH0	Force Control Voltage Output.
40	MEASI1H	DUT Current Sense Inputs (High Sense).
41	FOH1	Force Control Voltage Output.
42	MEASI2H	DUT Current Sense Inputs (High Sense).
43	FOH2	Force Control Voltage Output.
44	MEASI3H	DUT Current Sense Inputs (High Sense).
45	FOH3	Force Control Voltage Output.
46	MEASI4H	DUT Current Sense Inputs (High Sense).
47	MEASI5H	DUT Current Sense Inputs (High Sense).
48	AV <sub>EE,B</sub>	Most Negative Supply Voltage.
49	FOH	External Force Driver Control Voltage Output.
50	AV <sub>CC,B</sub>	Most Positive Supply Voltage.
51	COMPOUT0	Compensation Capacitor 0 Output.
52	COMPOUT1	Compensation Capacitor 1 Output.
53	COMPOUT2	Compensation Capacitor 2 Output.
54	COMPIN0	Compensation Capacitor 0 Input.
55	COMPIN1	Compensation Capacitor 1 Input.
56	COMPIN2	Compensation Capacitor 2 Input.
57, 59	REFGND	Analog Input/Output Reference Ground.
58	MEASOUT	Multiplexed DUT Voltage/Current Sense Output. See the Measured Parameter section.
60	MEASIOUT	DUT Current Sense Output.
61	MEASVOUT	DUT Voltage Sense Output.
62	FIN	Force Control Voltage Input.
63	CLH	Upper Clamp Voltage Input CLH > CLL.
64	CLL	Lower Clamp Voltage CLL < CLH.

TYPICAL PERFORMANCE CHARACTERISTICS

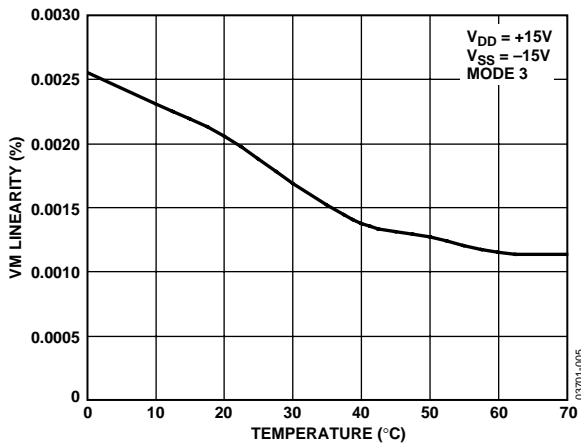

Figure 5. Voltage Sense Amplifier Linearity vs. Temperature

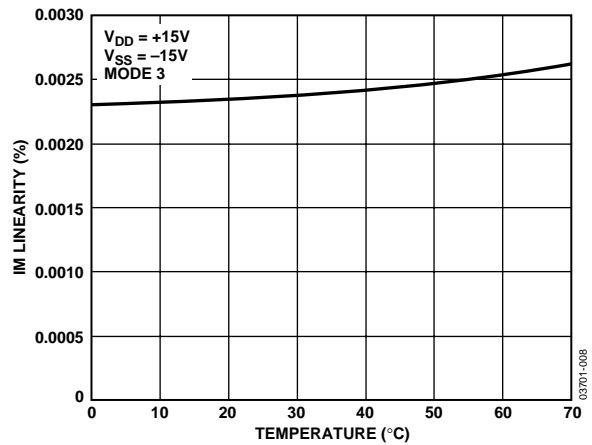

Figure 8. Current Sense Linearity vs. Temperature

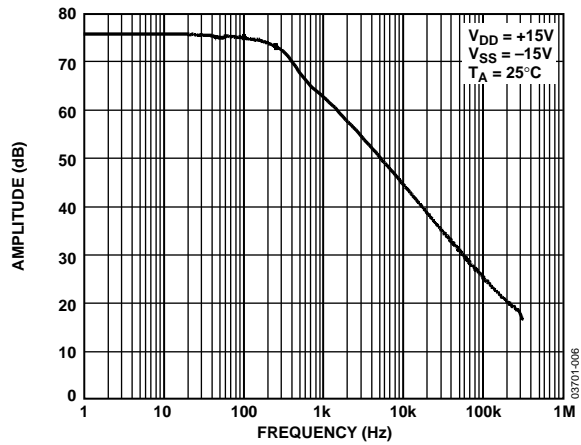

Figure 6. Voltage Sense Amplifier CMRR vs. Frequency

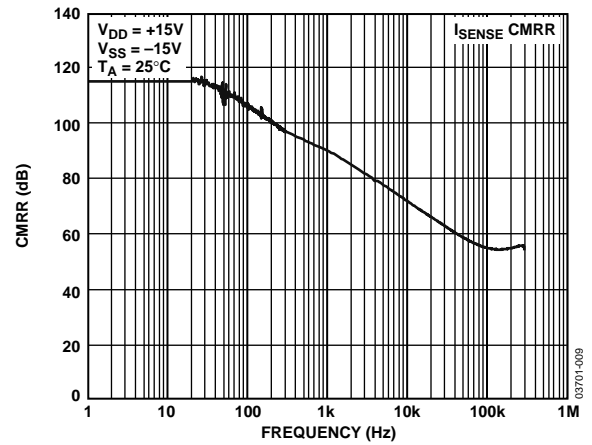

Figure 9. Current Sense Amplifier CMRR vs. Frequency

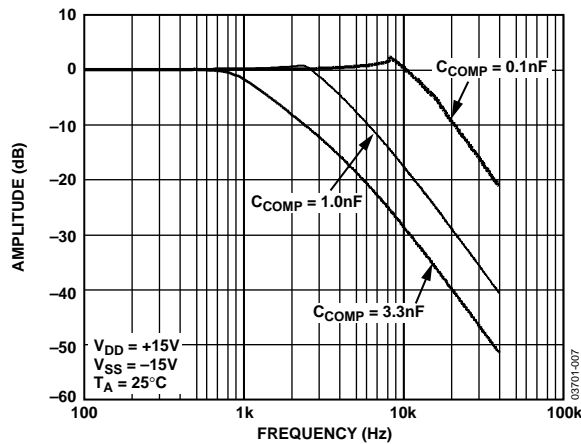

Figure 7. Force Amplifier Bandwidth, Mode 0 (4  $\mu$ A)

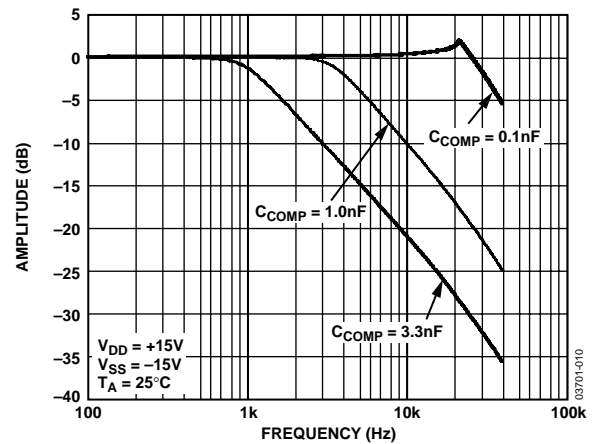

Figure 10. Force Amplifier Bandwidth, Mode 1 (40  $\mu$ A)

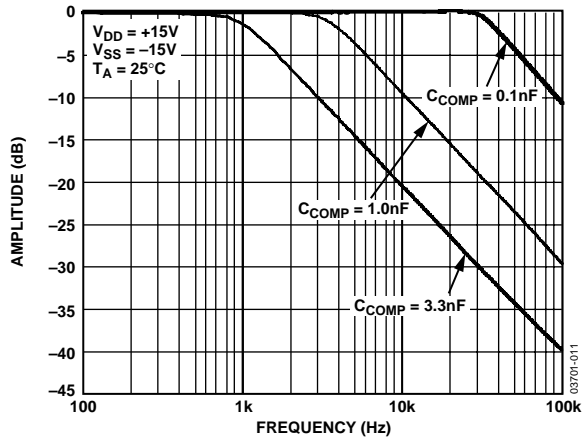

Figure 11. Force Amplifier Bandwidth, Mode 2 (400  $\mu$ A)

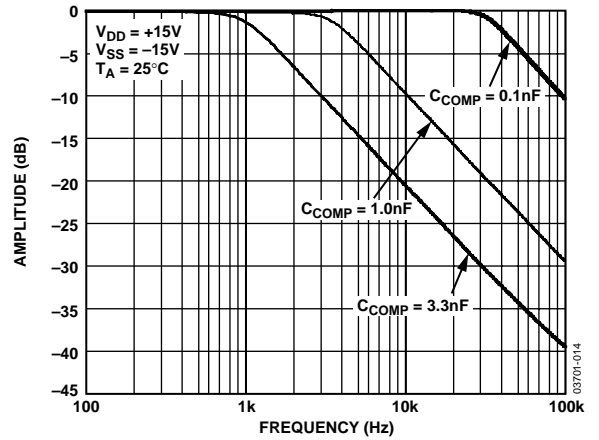

Figure 14. Force Amplifier Bandwidth, Mode 3 (4 mA)

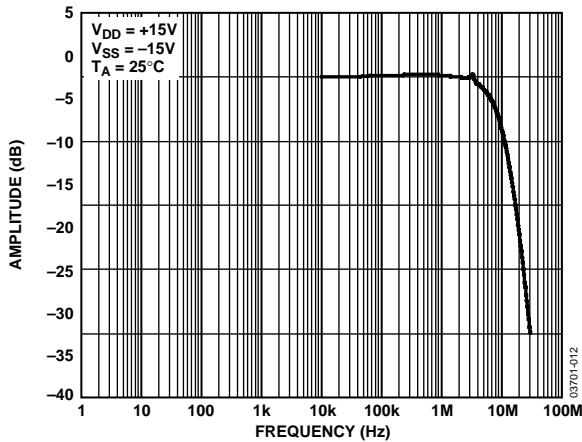

Figure 12. Guard Amplifier Bandwidth

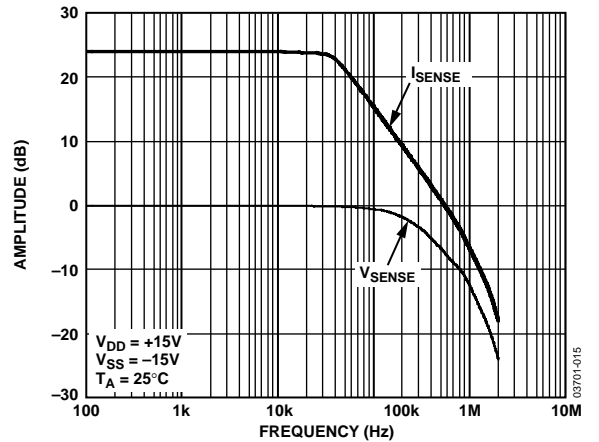

Figure 15. Voltage Sense and Current Sense Amplifier Bandwidths

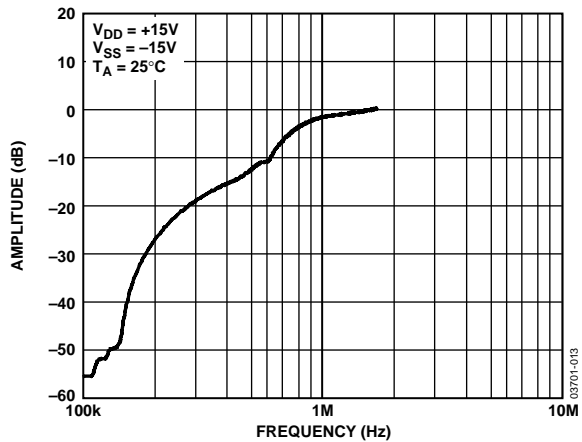

Figure 13. Current Sense Amplifier AC PSRR

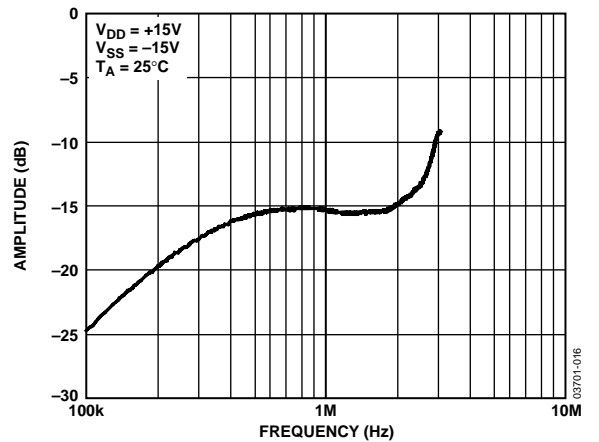

Figure 16. Force Amplifier AC PSRR, Mode 3,  $C_{COMP} = 100$  pF

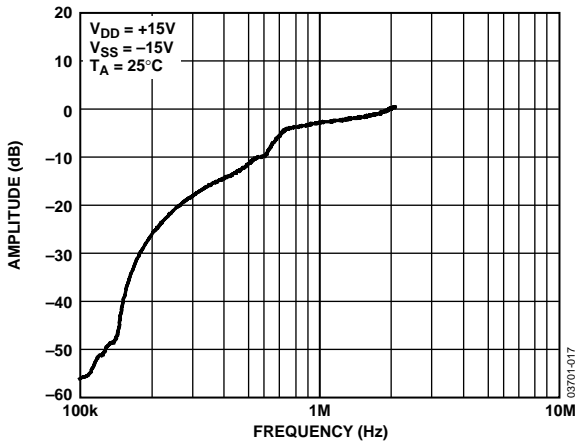

Figure 17. Voltage Sense Amplifier AC PSRR

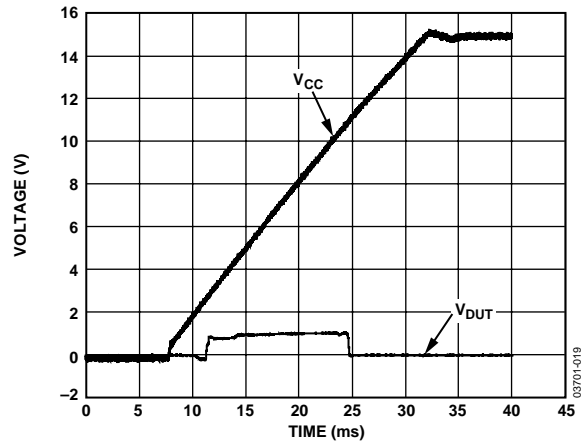

Figure 19. Power Up

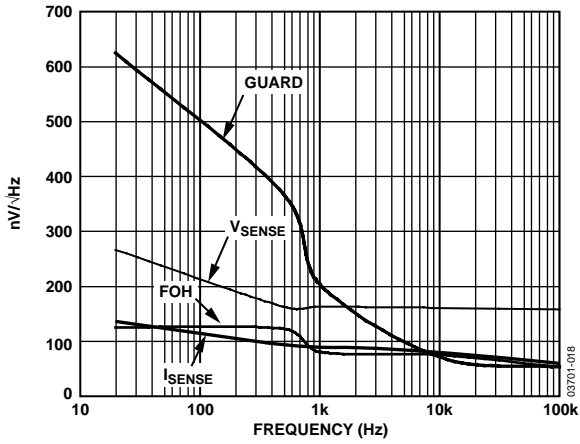

Figure 18. Noise Spectral Density

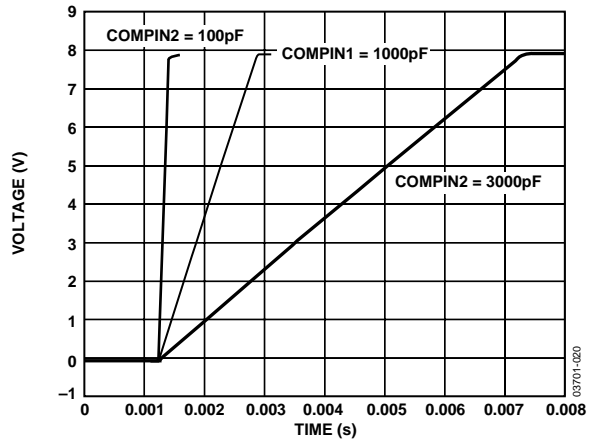

Figure 20. Settling Time, Mode 2

## THEORY OF OPERATION

The AD5520 is a single-channel per pin parametric measurement unit (PPMU) for use in semiconductor automatic test equipment. It contains programmable modes to force a pin voltage and measure the corresponding current (FVMI), force current measure voltage (FIMV), force current measure current (FIMI), force voltage measure voltage (FVMV), and force nothing measure voltage (FNMV). The PPMU can force or measure a voltage from  $-11\text{ V}$  to  $+11\text{ V}$ . It can force or measure currents up to  $6\text{ mA}$  using the internal amplifier, while the addition of an external amplifier enables higher current ranges. External resistors allow users to choose the optimum ranges for their needs.

The device provides a force sense capability to ensure accuracy at the tester pin. A guard output is also available to drive the shield of a force/sense pair.

The AD5520 has an on-board window comparator that provides two bits of useful information, DUT too low or too high. Also provided on the chip is clamp circuitry that flags via CLHDETECT and CLLDETECT if the voltage applied to FIN or across the DUT exceeds the voltage applied to CLL and CLH.

On-chip is clamp circuitry that clamps the output of the force amplifier if the voltage at MEASIOUT and MEASVOUT exceeds CLL or CLH.

## INTERFACE

The AD5520 PPMU is controlled via a number of digital inputs, which are discussed in detail in the following sections. All inputs are TTL-compatible.  $\overline{CS}$  is used to select the device while  $\overline{STB}$  (active low input) latches data available on the other digital inputs and updates any required digital outputs. The rising edge of  $\overline{STB}$  triggers sequence inputs. The remaining digital inputs control the function of the PMU. They also determine which measure mode the PMU is in, the compensation capacitor used, and the selected current range.

### STANDBY MODE

The AD5520 can be placed into standby mode via the standby logic input. In this mode, the force amplifier is disconnected from the force input (FIN). In addition, the switch in series with the force output pins (FOHx) is opened, and the current measure amplifier is disconnected from the sense resistors. The voltage measure amplifier is still connected across the DUT; therefore, DUT voltage measurements may still be made while in standby mode. Figure 21 shows the configuration of the PMU while in standby mode.

Table 5. Standby Mode

Standby	Function
Low	Normal Force Mode
High	Standby Mode

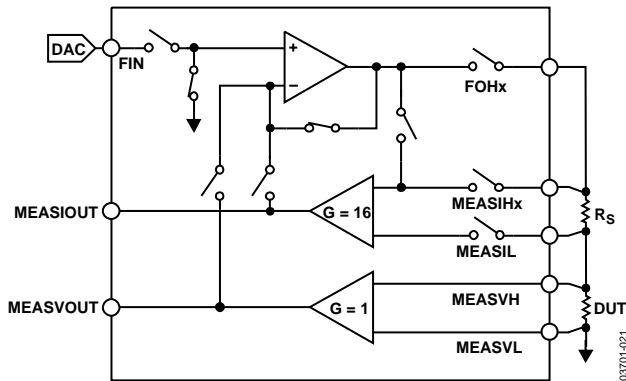

Figure 21. PMU in Standby Mode

### FORCE VOLTAGE OR FORCE CURRENT

FSEL is an input that determines whether the PPMU forces a voltage or current.

Table 6. FSEL Function

FSEL	Function
Low	Voltage Force and Current Clamp with MEASVOUT Voltage
High	Current Force and Voltage Clamp with MEASVOUT Voltage

### MEASURED PARAMETER

MEASOUT is a muxed output that tracks the sensed parameter. MSEL (digital input) connects the MEASOUT to the output of the current sense amplifier or the voltage sense amplifier, depending on which is the measured parameter of interest.

The MEASOUT pin is connected back to an ADC to allow the measured value to be converted to a digital code.

Table 7. MEASOUT Connected to Voltage or Current

MSEL	Function
Low	MEASOUT = DUT Voltage
High	MEASOUT = DUT Current

The MEASOUT pin can also be made high impedance through the MOEB logic input.

Table 8. MOEB Allows MEASOUT to Go High Impedance

MOEB	Function
Low	Enable MEASOUT Output
High	Hi-Z MEASOUT Output

### CURRENT RANGES

A number of current ranges are possible with the AD5520. The AM0, AM1, and AM2 pins are digital inputs used to establish full-scale current range of the PMU.

Table 9. Selection of Current Range

AM0	AM1	AM2	Function
Low	Low	Low	Current Range MODE0 (4 $\mu$ A)
High	Low	Low	Current Range MODE1 (40 $\mu$ A)
Low	High	Low	Current Range MODE2 (400 $\mu$ A)
High	High	Low	Current Range MODE3 (4 mA)
Low	Low	High	Current Range MODE4 (External Buffer Mode)
High	Low	High	Current Range MODE5 (External Buffer Mode)
Low	High	High	Standby (Same as STANDBY = High)
High	High	High	Standby (Same as STANDBY = High)

### RS SELECTION

The AD5520 is designed to ensure the voltage drop across each of the  $R_s$  resistors is less than  $\pm 500$  mV when maximum current is flowing through them. To support other current ranges, these sense resistor values can be changed. The force amplifier can drive a maximum of 6 mA. It is not recommended to increase the maximum current above the nominal range.

The two external current ranges use an external buffer to drive higher current. The example in Figure 26 uses 40 mA and 160 mA ranges. These ranges can be changed to suit user requirements for a high current range.

## FORCE CONTROL AMPLIFIER

The force control amplifier requires external capacitors connected between the COMPOUTx and COMPINx pins. For stability with large capacitance at the DUT, the largest capacitance value (3000 pF) should be selected. The force control amplifier should always contribute the dominant pole in the control loop. Settling times increase with larger capacitances. ACx inputs select which external compensation capacitor is used.

**Table 10. AC0, AC1 Compensation Capacitor Selection**

AC0	AC1	Function
Low	Low	Select External Compensation Capacitor 0
High	Low	Select External Compensation Capacitor 1
Low	High	Select External Compensation Capacitor 2

## COMPARATOR FUNCTION AND STROBING

The AD5520 has an on-board window comparator that provides two bits of useful information, DUT too low or DUT too high. CPSEL is the digital input that controls this function, selecting whether it should compare to the voltage sense or the current sense amplifier.

**Table 11. Comparator Function Select**

CPSEL	Function
Low	Compare CPL, CPH to MEASVOUT
High	Compare CPL, CPH to MEASIOU

After CPSEL has selected which amplifier output is of interest, logic input CPCK is used to initiate comparator sampling and update the logic outputs CPOH and CPOL. This indicates whether the voltages at MEASIOU or MEASVOUT have exceeded voltages set at CPL or CPH (thus providing DUT too high or DUT too low information). A rising edge on STB is required to clock the CPOH and CPOL data out.

**Table 12. CPCK Synchronous Logic Outputs**

CPOH	Function
Low	MEASVOUT or MEASIOU < CPH MEASVOUT or MEASIOU > CPH
CPOL	Function
Low	MEASVOUT or MEASIOU > CPL MEASVOUT or MEASIOU < CPL
High	

## CLAMP FUNCTION

Clamp circuitry, which is also included on-chip, clamps the force amplifier's output if the voltage or current applied to the DUT exceeds the clamp levels, CLL and CLH. The clamp circuitry also comes into play in the event of a short or open circuit. When in force current range, the voltage clamps protect the DUT from an open circuit. Likewise, when forcing a voltage and a short circuit occurs, the current clamps protect the DUT. The clamps also function to protect the DUT if a transient voltage or current spike occurs when changing to a different operating mode, or when programming the device to a different current range.

The digital output flags, which indicate a clamp limit has been hit, are CLHDETECT for the upper clamp, and CLLDETECT output for the lower clamp.

**Table 13. Clamp Detect Outputs**

CLHDETECT	Function
Low	Upper Clamp Inactive
High	Upper Clamp Active
CLLDETECT	Function
Low	Lower Clamp Inactive
High	Lower Clamp Active

## HIGH CURRENT RANGES

With the use of an external high current amplifier, two high current ranges are possible. The current range values can be set as required in the application through appropriate selection of the sense resistors connected between MEASI5H, MEASI4H, and MEASIL. When one of these high current ranges (Mode 4 or Mode 5) is selected via the AMx control lines, the appropriate QM4 or QM5 output is enabled. As a result, these outputs can be used to control relays connected in series with the high current amplifier, as shown in Figure 26.

**Table 14. High Current Range Logic Outputs**

QM4	QM5	Function
High	Low	Current Range Mode 4 Enable Output
Low	High	Current Range Mode 5 Enable Output

# CIRCUIT OPERATION

## FORCE VOLTAGE

Most PMU measurements are performed while in force voltage and measure current modes; for example, when the device is used as a device power supply, or in continuity or leakage testing. In the force voltage mode, the voltage at analog input FIN is mapped directly to the voltage forced at the DUT.

When in force voltage and measure current modes, the maximum voltage applied to the input corresponds to the maximum current outputs. Figure 22 shows the transfer function when forcing a voltage.

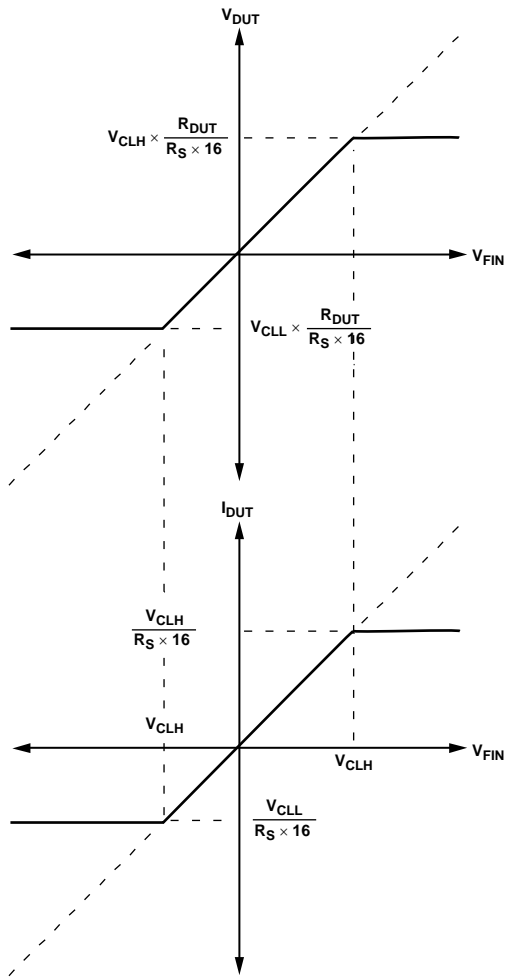
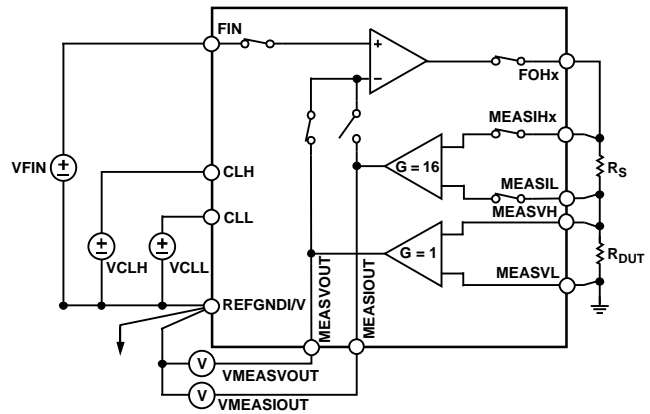

Figure 22. Force Voltage Transfer Function

03701-022

## MEASURE CURRENT

Figure 23 shows a simplified diagram of the PMU when in force voltage mode. The control loop consists of the force amplifier with the voltage sense amplifier making up the feedback path. Current flowing through the DUT is measured by sensing the current flowing through a selectable sense resistor, which is in series with the DUT. The current sense amplifier (Gain = 16) generates a voltage at its output, which is proportional to the current flowing through the DUT. This voltage is compared to the CLL and CLH levels to ensure the clamp voltages have not been exceeded. Strobing CPHK and STB provides information about the voltage level with respect to the comparator levels, CPH and CPL.



CONDITION	$V_{CLH} > I_{DUT} \times R_S \times 16$ $V_{CLL} < I_{DUT} \times R_S \times 16$	$V_{CLH} < I_{DUT} \times R_S \times 16$ $V_{CLL} < I_{DUT} \times R_S \times 16$	$V_{CLH} > I_{DUT} \times R_S \times 16$ $V_{CLL} > I_{DUT} \times R_S \times 16$
OUTPUT	$V_{DUT} = V_{FIN}$	$V_{DUT} = V_{CLH}$	$V_{DUT} = V_{CLL}$

Figure 23. Force Voltage, Measure Current Mode

03701-023



**FORCE CURRENT**

In force current mode, the voltage at FIN is now converted to a current through the following relationship:

$$\text{Force Current} = V_{FIN} / (R_{SENSE} \times 16)$$

Figure 24 shows a simplified diagram of the PMU when in force current mode. The control loop consists of the force amplifier with the current sense amplifier making up the feedback path. In this case, voltage at the DUT is sensed across the voltage measure amplifier (Gain = 1) and presented at the MEASVOUT output.

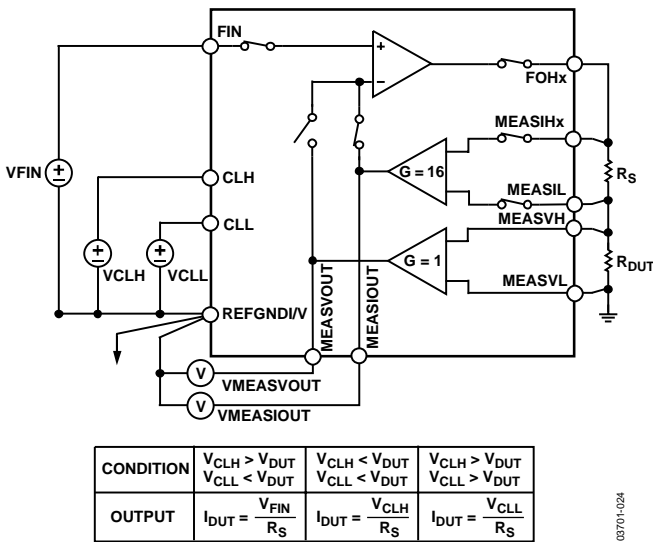

Figure 24. Current Force, Voltage Measure Mode

**MEASURE VOLTAGE**

A DUT voltage is tested via the voltage measure amplifier by a window comparator to ensure that CPH and CPL levels are not exceeded. In addition, the DUT voltage is automatically tested against the voltage levels at the clamp, and clamp flags are enabled if the DUT voltage exceeds either of the levels.

**SHORT CIRCUIT PROTECTION**

The AD5520 is designed to withstand a direct short circuit on any of the amplifier outputs.

Figure 25 illustrates the transfer function of the current force mode.

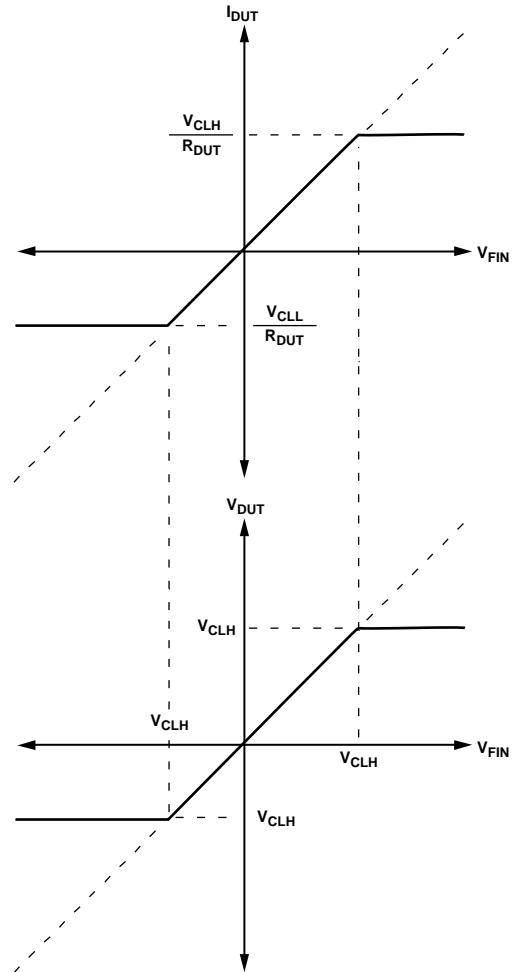

Figure 25. Current Force Transfer Function

## SETTLING TIME CONSIDERATIONS

Fast throughput is a key requirement in automatic test equipment because it relates directly to the cost of manufacturing the DUT; thus reducing the time required to make a measurement is of greatest importance. When taking measurements using a PMU, the limiting factor is usually the time it takes the output to settle to the required accuracy so a measurement can be taken. DUT capacitance, measurement accuracy, and the design of the PMU are the major contributors to this time.

Figure 26 shows a simplified block diagram of the AD5520 PMU. In brief, the device consists of a force control amplifier, access to a number of selectable sense resistors, a voltage measure instrumentation amplifier, and a current measure instrumentation amplifier. To optimize the performance of the device, there are also nodes provided where external compensation capacitors are added. As mentioned, making an accurate measurement in the fastest time while avoiding overshoots and ringing is the key requirement in any automatic test equipment (ATE) system. Doing so provides challenges, however. The external compensation capacitors set up different settling times or bandwidths on the force control amplifier, and while one compensation capacitor value may suit one range, it may not suit other ranges. To optimize measurement performance and speed, differences in signal behavior on each range and frequency of use of each range need to be taken into account.

When selecting a faster settling time, there is a trade-off. A small compensation value results in faster settling, but may incur penalties in overshoots or ringing at the DUT. Compensation capacitor selection should be optimized to ensure minimum overshoots while still giving decent settling time performance.

While careful selection of the compensation capacitor is required to minimize the settling time, another factor can greatly contribute to the overall settling of the loop if the feedback loop is broken in some manner, and the force control amplifier goes to either the positive or negative rails. There is a finite amount of time required for the amplifier to recover from this condition, typically 85  $\mu$ s, which adds to the settling of the loop. Ensuring that the force control amplifier never goes into saturation is the best solution. This solution can be helped by putting the device into standby mode any time the operating mode or range selection is changed. In addition, ensure that the selected output range can supply the required current needed by the DUT.

## PCB LAYOUT AND POWER SUPPLY DECOUPLING

In any circuit where accuracy is important, careful consideration to the power supply and the ground return layout helps to ensure the rated performance. The printed circuit board on which the AD5520 is mounted should be designed so that the analog and digital sections are separated and confined to certain areas of the board. If the PMU is in a system where multiple devices require an AGND-to-DGND connection, the connection should be made at one point only. The star ground point should be established as close as possible to the device.

This PMU should have ample supply bypassing of 10  $\mu\text{F}$  in parallel with 0.1  $\mu\text{F}$  on the supply and should be located as close as possible to the package, ideally right up against the device. The 0.1  $\mu\text{F}$  capacitor should have low effective series resistance (ESR) and effective series inductance (ESI), such as the common ceramic types that provide a low impedance path to ground at high frequencies, to handle transient currents due to internal logic switching. Low ESR (1  $\mu\text{F}$  to 10  $\mu\text{F}$ ) tantalum or electrolytic capacitors should also be applied at the supplies to minimize transient disturbance and filter out low frequency ripple.

Fast switching signals, such as clocks, should be shielded with digital ground to avoid radiating noise to other parts of the board and should never be run near the reference inputs.

Avoid crossover of digital and analog signals. Traces on opposite sides of the board should run at right angles to each other. This reduces the effects of feedthrough through the board. A microstrip technique is by far the best but not always possible with a double-sided board. In this technique, the component side of the board is dedicated to the ground plane while signal traces are placed on the solder side.

It is good practice to use compact, minimum lead length PCB layout design. Leads to the input should be as short as possible to minimize IR drops and stray inductance.

## TYPICAL CONNECTION CIRCUIT FOR THE AD5520

Figure 26 shows the AD5520 as connected in a typical application. The external components required are three compensation capacitors and six sense resistors, depending on the number of ranges required. If high current ranges >6 mA are required, an external amplifier must be used with relays (or some form of high current switch) to switch in the different current ranges to the DUT. Other components are also required to make the PMU function.

The PMU requires a number of discrete voltage levels: five DAC levels for each PMU used in the system, two levels each for the comparator and clamps, and one voltage level for the AD5520 force input voltage. To use the information measured at the DUT, an ADC such as the AD7665 (a 16-bit ADC), must be connected to the MEASOUT pin to convert the measured current or voltage to digital for analysis.

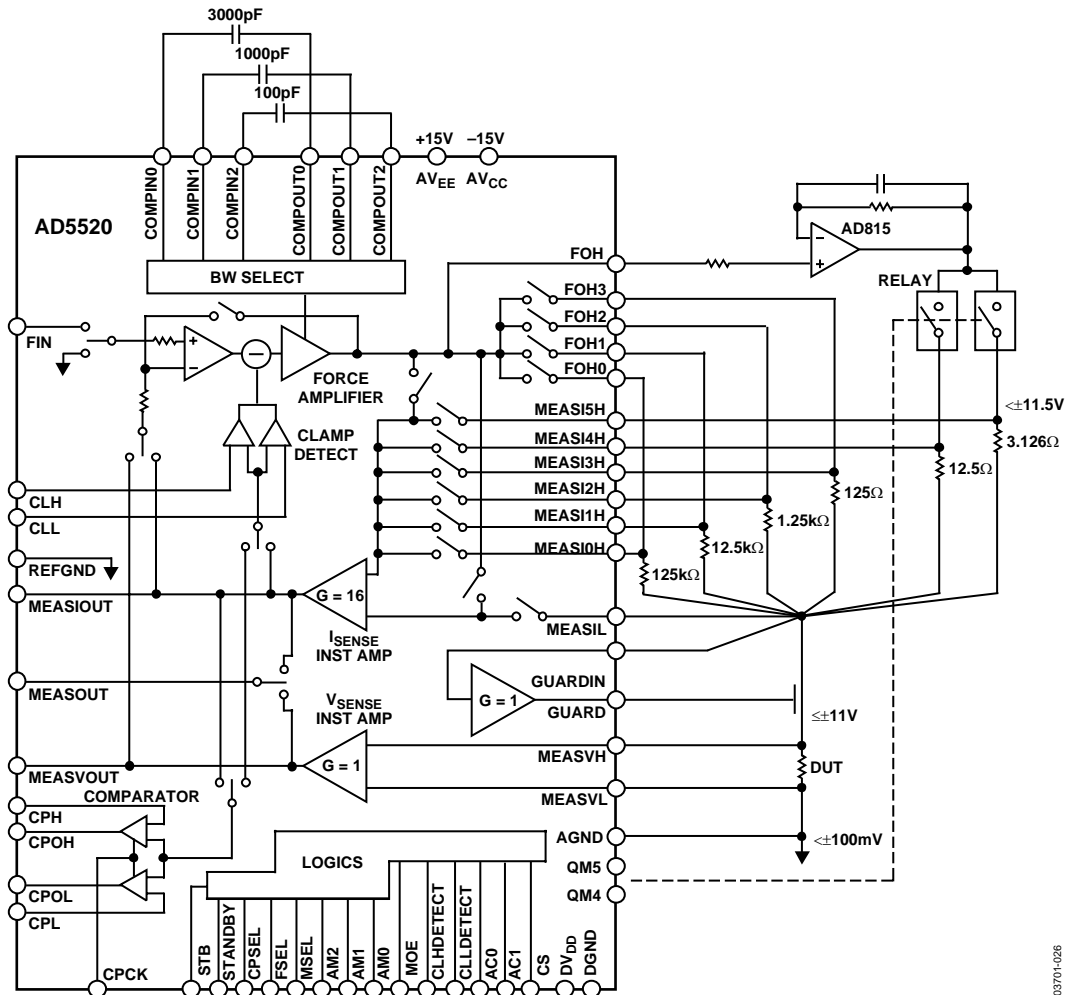

Figure 26. Typical Configuration of the AD5520 as Used in an ATE Circuit

## TYPICAL APPLICATION CIRCUIT

Figure 27 shows the AD5520 as in an ATE system. This device can be used as a per pin parametric unit in order to speed up the rate at which testing can be done. It can also be used as a DUT power supply, as shown in the application circuit.

The central PMU shown in the block diagram (Figure 27) is usually a highly accurate PMU and is shared among a number of pins in the tester. In general, many discrete levels are required in an ATE system for the pin drivers, comparators, clamps, and active loads. DAC devices, such as the AD5379, offer a highly integrated solution for a number of these levels. The AD5379 is a dense 40-channel DAC designed with high channel requirements, such as ATE.

The flexible function of the AD5520 also makes it suited for use in instrumentation applications such as source measure units. Source measure units are programmable instruments capable of sourcing and measuring voltage or current simultaneously. The AD5520 provides a more integrated solution in such equipment.

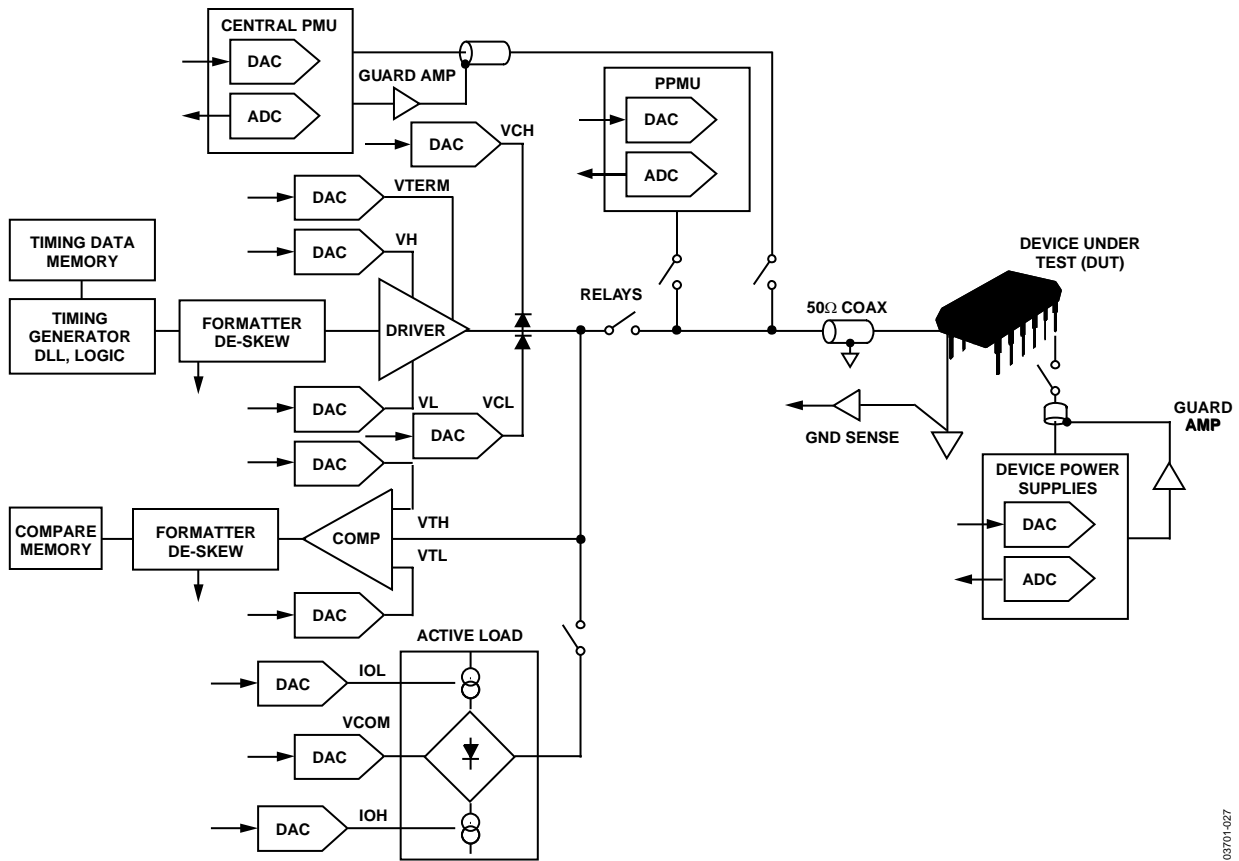

Figure 27. Typical Application ATE Circuit

03701-027

## EVALUATION BOARD FOR THE AD5520

A full-featured evaluation kit is available for the AD5520. It includes an evaluation board with direct hookup via a 36-way Centronics connector to a PC. PC-based software to control the AD5520 is also part of the evaluation kit. The evaluation board schematic is shown in Figure 28.

Note that  $V_{DD}$  and  $V_{SS}$  must provide sufficient headroom for the force and measure voltage range. In addition to the supply voltages for the evaluation board, it is necessary to provide the voltage levels for the clamp, comparator, and the force input pins (CLL, CLH, CPL, CPH, and FIN). SMB connections are provided for these voltage inputs. To use the evaluation board, it is also necessary to provide a DUT connected via the gold pins.

Both AGND and DGND inputs are provided on the board. The AGND and DGND planes are connected at one location close to the AD5520. It is recommended not to connect AGND and DGND elsewhere in the system to avoid ground loop problems. REFGND is routed back to AGND at the power block to maintain a clean ground reference for accurate measurements.

Each supply is decoupled to the relevant ground plane with 10  $\mu\text{F}$  and 0.1  $\mu\text{F}$  capacitors. The device supply pin is again decoupled with a 10  $\mu\text{F}$  and 0.1  $\mu\text{F}$  capacitor pair to the relevant ground plane.

Care should be taken when replacing devices to ensure that the pins line up correctly with the PCB pads.

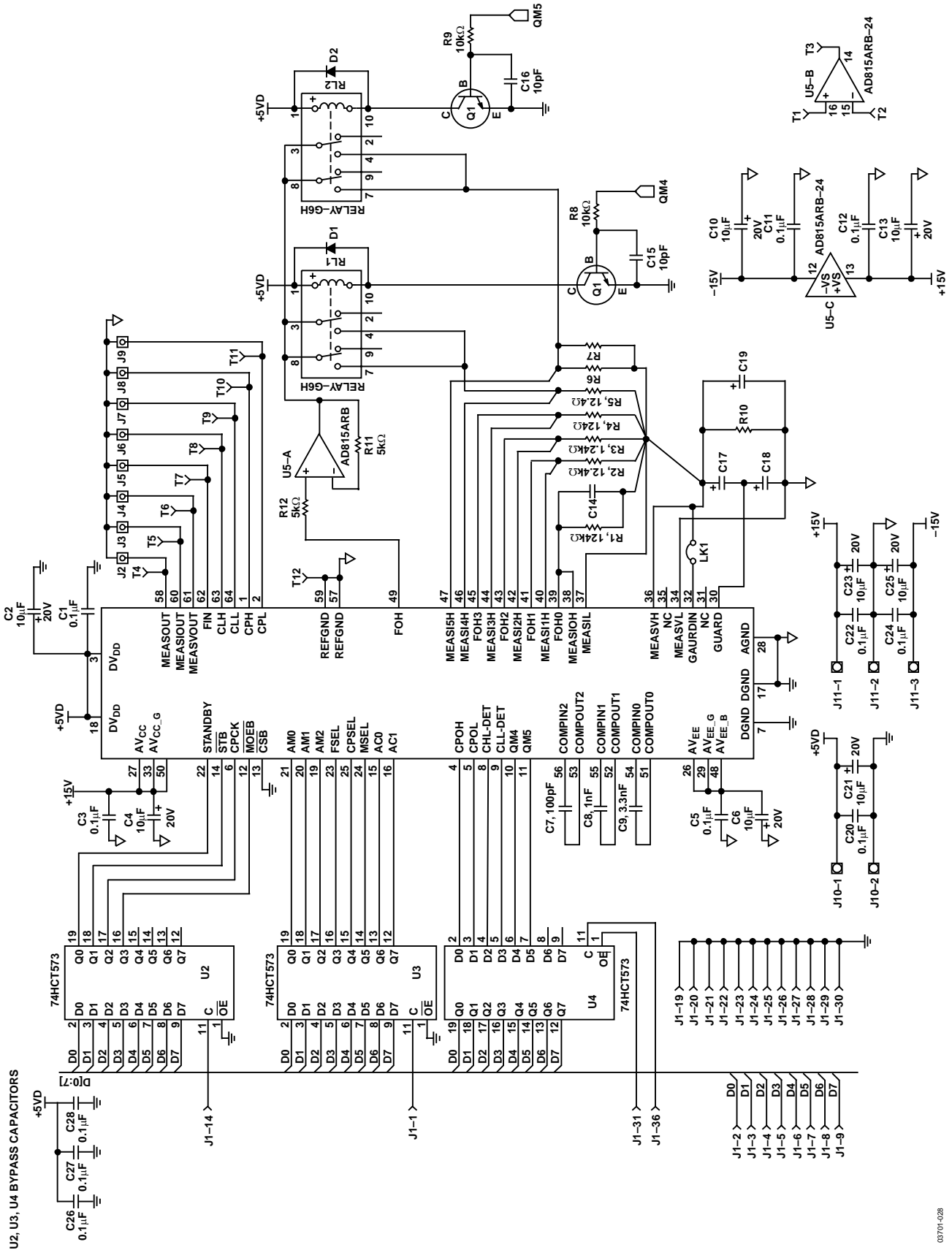
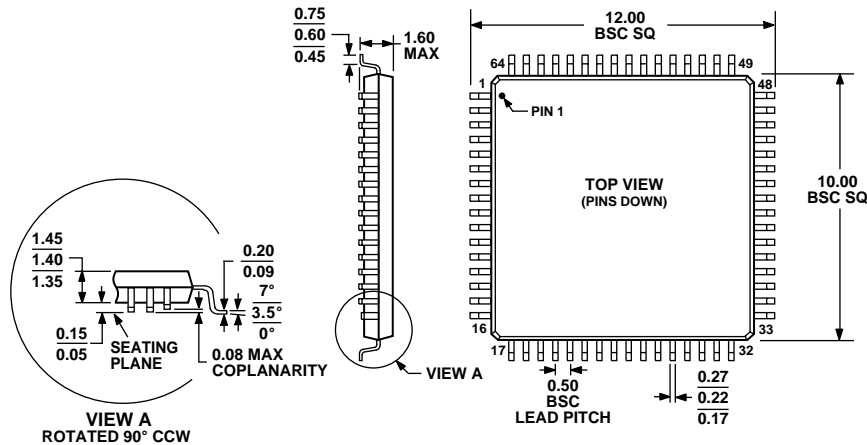

Figure 28. Evaluation Board Schematic

OUTLINE DIMENSIONS



COMPLIANT TO JEDEC STANDARDS MS-026-BCD

Figure 29. 64-Lead Low Profile Quad Flat Package [LQFP] (ST-64-2)

Dimensions shown in millimeters

ORDERING GUIDE

Model	Temperature Range	Package Description	Package Option
AD5520JST	0°C to 70°C	64-Lead Low Profile Quad Flat Package [LQFP]	ST-64-2
AD5520JST-REEL	0°C to 70°C	64-Lead Low Profile Quad Flat Package [LQFP]	ST-64-2
AD5520JSTZ-REEL <sup>1</sup>	0°C to 70°C	64-Lead Low Profile Quad Flat Package [LQFP]	ST-64-2
EVAL-AD5520EB		Evaluation Board and Software	

<sup>1</sup> Z = Pb-free part.